



CRST410 0/1

尺寸(Dimensions):15.7X11X12mm

特点 Features

- 1,线圈功耗低 Low coil power consumption.
- 2,高灵敏度 High sensitivity.
- 3,体积小,重量轻 Small size,Light weight .
- 4,可直接焊接在印刷细路板中 PC board mounting.
- 5,可用于自动装置,通讯设备,无线电遥控,声控玩具 Suitable for automation facilities,telecommunication equipment,household electrical appliance,wireless radio remote control,sound control toys application etc

订货信息 Ordering information

CRST4100 -C-S-DC12V-L

1 2 3 4 5

- 1,型号 Part number: CRST4100 & CRST4101
- 2,触点形式 Contact arrangement:1C
- 3,封装形式:S:试水式;无:防尘式 Enclosure: S:Sealed type; Z:Dust cover
- 4,线圈额定电压 Coil Rated voltage(V):DC:3,5,6,9,12,24
- 5,线圈功耗 Coil power consumption:无 Nil 0.36W(标准 Standard);L:0.2W(高灵敏度 High sensitivity)

触点数据 Contact data

触点形式 Contact Arrangement	1C	
触点材料 Contact Material	AgNi, AgCdO	
触点负载(阻性) Conatct Rating(Resistive)	UL: 1A/240VAC;2A/120VAC;2A/24VDC CQC: 3A/250VAC;3A/28VDC	
最大切换功率 Max. Switching Power	30W 600VA	
最大切换电压 Max. Switching Voltage	28VDC 250VAC 最大切换电流 Max. Switching Current:5A	
触点阻性或压降 Contact Resistance or Voltage Drop	≤50mΩ	
寿命 Operation Life	电气 Electrical	10 ⁵
	机械 Mechanical	10 ⁷

线圈参数 Coil Parameter

线圈电压 Coil voltage(VDC)		线圈电阻 Coil Resistance	吸合电压 VDC(最大) Pick up Voltage VDC(Max) (额定电压的 75%) (75% of rated voltage)	释放电压 VDC Release voltage VDC(Min) (额定电压的 10%) (10% of rated voltage)	线圈功耗 Coil power consumption (W)	动作时间 Operate Time (mS)	释放时间 Release Time (mS)		
额定 Rated	最大 Max	Ω ±10%							
5	5.5	125	3.75	0.5	0.2	≤10	≤5		
9	9.9	405	6.75	0.9					
12	13.2	720	9.00	1.2					
24	26.5	2880	18.0	2.4					
5	5.5	75	3.75	0.5	0.36				
9	9.9	225	6.75	0.9					
12	13.2	400	9.00	1.2					
24	26.5	1600	18.0	2.4					

注意:1,使用的线圈电压低于线圈额定电压时将会损害继电器的工作.

2,吸合,释放电压仅供检测用,不是设计的使用指标.

Caution:1,The use of any coil voltage less than the rated coil voltage will compromise the operation of the relay.

2,Pick up and release voltage are for test purposes only and are not be used as design criteria.

技术特性 Operation condition

绝缘电阻 Insulation Resistance		100MΩ (at 500VDC)
介质耐压	断开触点间 Between Contacts	500VAC 1min
Dielectric Strength	触点与线圈间 Between Contacts and Coil	1000VAC 1min
耐冲击	动作极限 Functional	98m/s ²
Shock Resistance	破坏极限 Destructive	980m/s ²
抗振性 Vibration Resistance		10~55Hz 1.5mm DA
环境温度 Ambient Temperature		-45~85℃
相当湿度 Relative Humidity		5%~85% RH
安装方式 Termination		PCB
封装方式 Construction		Plastic sealed, Flux proofed
质(重)量 Unit weight		Approx.5g

外形尺寸 Dimensions(mm/Inch)

Outline Dimensions

CRST4100

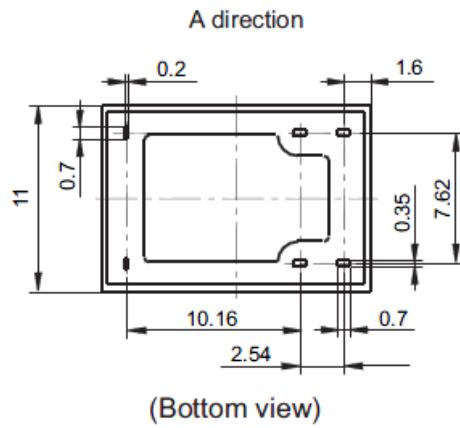
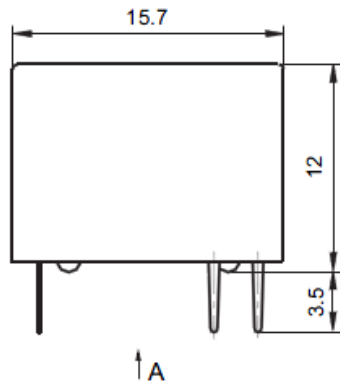

Wiring Diagram
(Bottom view)

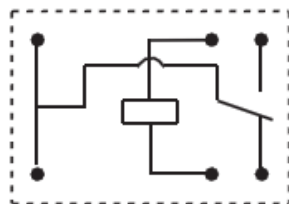

PCB Layout
(Bottom view)

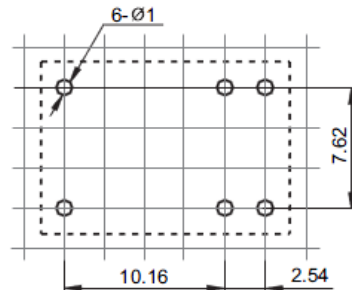

Outline Dimensions

CRST4101

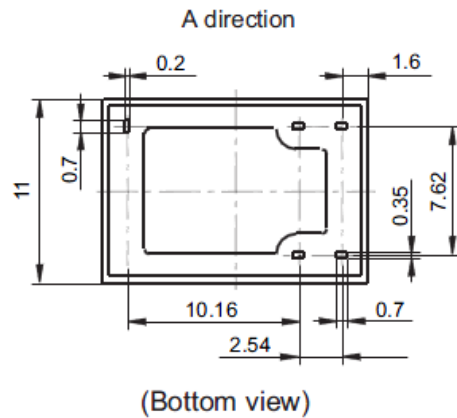
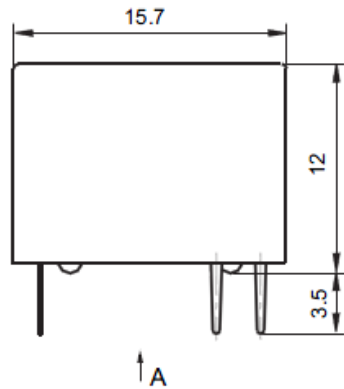

Wiring Diagram (Bottom view)

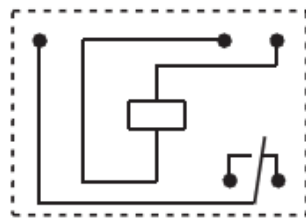

PCB Layout (Bottom view)

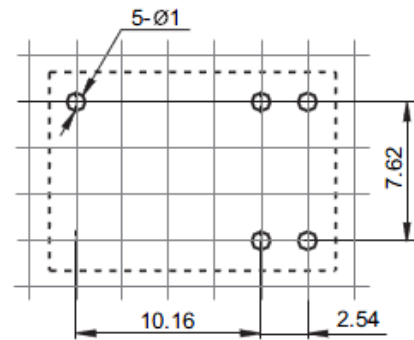

Dimension Tolerance: <1mm: $\pm 0.2\text{mm}$
 1-5mm: $\pm 0.3\text{mm}$
 >5mm: $\pm 0.5\text{mm}$

参考数据 Reference Data

ENDURANCE CURVE

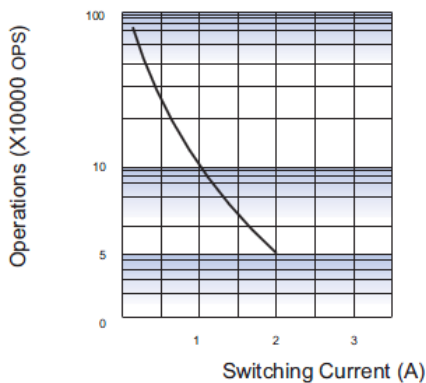

COIL TEMPERATURE RISE

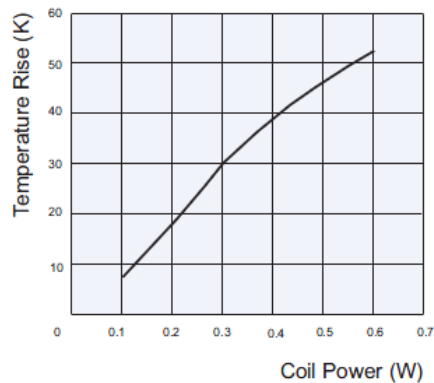

OPERATE TIME

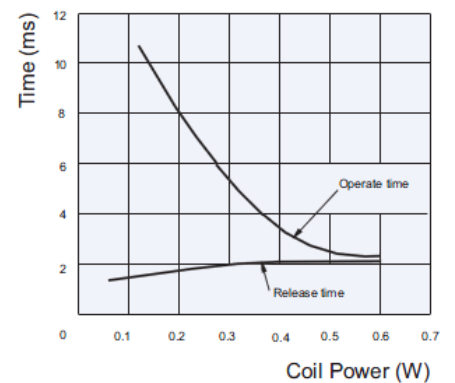

Test conditions:

Resistive load, Room temp., 1s on 9s off.